

Operating Instructions

High-Performance Rake

RS 640
RS 640-S

RS 710
RS 710-S

RS 740-V
RS 740-VS



This Operating Instruction contains valuable and important information. Read this instruction before using the machine and observe the instruction provided in order to ensure effective and safe working.

Keep these Operating instruction in a safe place. Every user of the high-performance rake must first familiarize himself or herself with the contents before beginning work.

Contents:

Scope of delivery	page 2
Technical data	page 2
Safety instructions	page 3
Initial operation	page 9
Hydraulics diagram	page 10
Hitching, Transport and Operating	page 11
Storing the high-performance rake	page 16
Care and Maintenance	page 17
Option Parts	page 19
Warning symbols	page 20

NIEMEYER

A G R A R T E C H N I K
NIEMEYER Agrartechnik GmbH

D-48477 Hörstel-Riesenbeck, H.-Niemeyer-Str. 52

Telefon 0 54 54 / 9 10-2 77 - Telefax 0 54 54 / 9 10-1 15

Internet: <http://www.NiemeyerWeb.de> -E-Mail: info@NiemeyerWeb.de

NIEMEYER

EC Declaration of Compliance
in accordance with EC Directive 89/ 392/EEC

We

H. NIEMEYER SÖHNE GMBH & CO. KG
H. Niemeyer-Str. 52
D-48477 Hörstel

declare on our sole responsibility that the product

Type: *

to which this declaration refers, complies with the relevant applicable
safety and health requirements of EC Directive 89/392/EEC.

* This information is contained in the original EC declaration of compliance.

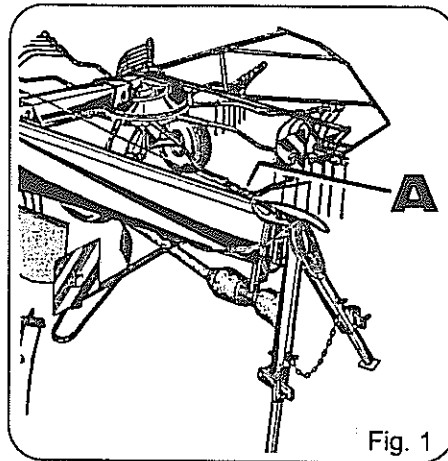

Each machine is provided with a serial plate (see fig. 1, pos. A) which contains details of the model (fig. 2, pos. C) serial number (fig. 2, pos. D) and year of manufacture (fig. 2, pos. E).

This information must be communicated for customer service or when reordering spare parts.

The weight given on the identification plate gives an indication of the type of lifting appliance required to raise the machine. The actual weight can be greater due to the addition of accessories.

Pos. F = Direction of rotation of the power take-off in driving direction, right (clockwise)

or

Pos. G = Direction of rotation of the power take-off in driving direction, left (anti clockwise).

The not marked turning speed and turning direction is suitable.

Pos. H = The maximum driving speed of the motor given for the tractor power take-off shaft may not be exceeded.

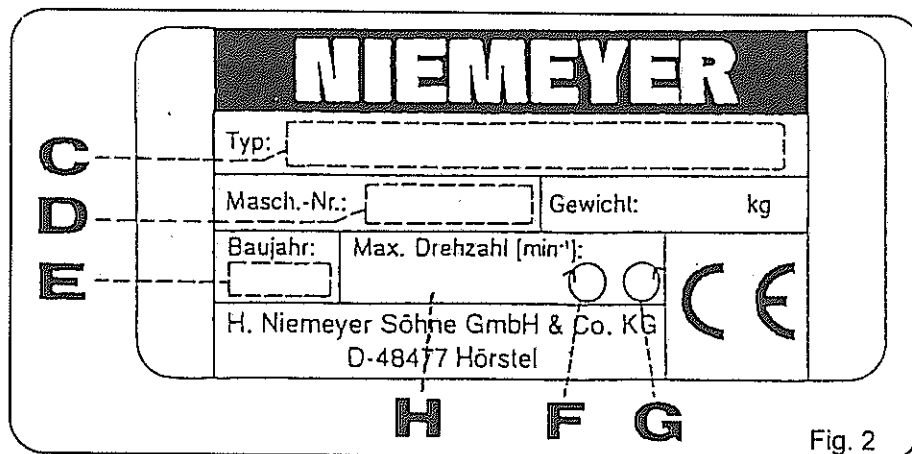

Scope of Delivery

1 High-performance rake RS 640

- 1 operating instruction
- 1 EC Declaration of Compliance

1 High-performance rake RS 640-S

- 1 operating instruction
- 1 EC Declaration of Compliance

1 High-performance rake RS 710

- 1 operating instruction
- 1 EC Declaration of Compliance

1 High-performance rake RS 710-S

- 1 operating instruction
- 1 EC Declaration of Compliance

1 High-performance rake RS 740-S

- 1 operating instruction
- 1 EC Declaration of Compliance

1 High-performance rake RS 740-VS

- 1 operating instruction
- 1 EC Declaration of Compliance

Technical Data

	RS 640 / RS 640-S	RS 710 / RS 710-S	RS 740-V / RS 740-VS
Weight* (basic machine)	approx. 1120 / 1140 kg	approx. 1200 / 1220 kg	approx. 1280 / 1300 kg
Max. drive speed	540 rpm	540 rpm	540 rpm
Dir. of rotation of P.T.O. shaft (in driving direction)	right	right	right
Noise emission value (under operating conditions)	< 70dB (A)	< 70dB (A)	< 70dB (A)
Working width	approx. 6,30 m	approx. 6,90 m	approx. 6,70 - 7,30 m
Transport width	approx. 2,30 m	approx. 2,50 m	approx. 2,50 m
Transport- /Storage height	approx. 3,80 / 3,15 m	approx. 3,90 / 3,25 m	approx. 3,80 / 3,15 m
Storage length	approx. 4,30 / 4,35 m	approx. 4,30 / 4,35 m	approx. 4,30 / 4,35 m
Tractor drive output	from 30 kW (40 hp)	from 30 kW (40 hp)	from 30 kW (40 hp)

* The stated weights can be increased by using additional parts.

Safety instructions



We have indicated all those instances in these operating instructions involving your safety with this symbol. Please let other users also know about all these safety instructions.

Proper Use

The high performance rake may only be used for the purposes intended (to handle mown straw lying on the ground). Otherwise the manufacturer accepts no liability whatsoever for resulting damage. Any other or additional use, such as raking together of pieces of wood, is considered not to be proper use. Use of the machine in accordance with its intended purpose also includes observance of operating conditions specified by the manufacturer and the undertaking of necessary care and maintenance work at the specified intervals.

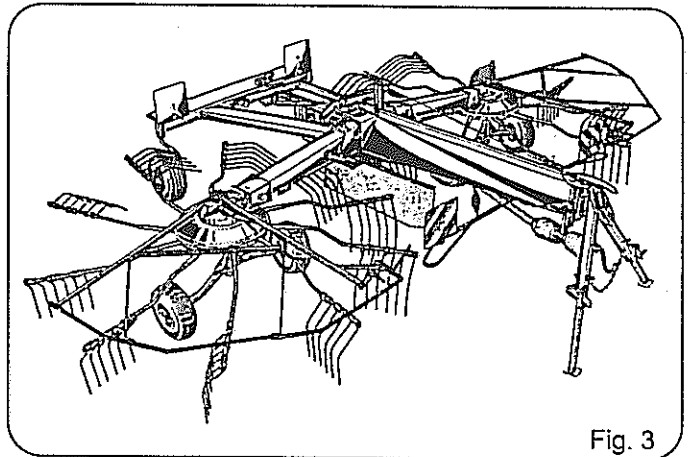

The high-performance rake may be used, serviced and repaired only by persons who are familiar with such work and aware of the hazards involved. The relevant accident prevention regulations and all other generally recognized technical safety, occupational safety and road traffic regulations must be complied with.

Road traffic regulations may stipulate that all machines are equipped with lighting when being transported on public roads and highways.

Basic rule



Please read the operating and safety instructions prior to initial start-up (see warning symbol on page 20, pos. C).

Check the implement for operation and road safety before each use.

Safety and Accident Prevention Regulations

General

1. As well as these Operating Instructions, also observe the generally valid safety and accident prevention regulations.
2. The attached warning signs and notices provide important information for safe operation; observance of the instructions contained on them is for your own safety!
3. When using public roads, observe all local road traffic regulations.
4. Before beginning work, familiarize yourself with all the features and control elements of the machine and their functions. It is too late to do this during operation !
5. The user's clothing should be tight-fitting. Avoid loose-fitting clothing!
6. To prevent the risk of fire, keep the machine clean!
7. Before the machine is lifted and the tractor sets off, check the immediate vicinity. Make sure you have sufficient visibility and watch out for children!
8. The carrying of passengers on the machine when working or in transit is not permitted.
9. Hitch the machine in accordance with regulations and only attach and secure it to the appliances for which it is intended.
10. When hitching and unhitching, set the support components to the appropriate positions! (stability!)
11. Particular care and attention is required when hitching and unhitching appliances to and from the tractor!
12. Always mount ballast weights in accordance with regulations and at the securing points provided!
13. Observe permissible axle loads and maximum laden weights!
14. Observe permissible transport dimensions!
15. Check and affix the necessary transport equipment, such as lighting, hazard warning signs and protective devices and guards!
16. Operating elements (cables, chains, linkages etc.) of remote-controlled devices must be aligned in such a way that they do not cause unintentional motion in any transit or working positions!
17. Make sure that the machine is in the specified condition for road travel, and secure it in accordance with manufacturer's regulations!
18. Never leave the driver's station whilst the machine is in motion!
19. The running speed of the machine must always be adapted to the environmental conditions! Avoid sudden cornering movements when driving up or down hill, or when driving transverse to the slope of the hill!
20. The handling, steering and braking characteristics of the tractor are affected by hitched machinery and ballast weights! You should therefore make sure of sufficient steerability and braking capability!
When cornering, take into account the overhang and the centrifugal mass of the machine!
- 21.

The machine may only be started up when all protective devices and guards have been mounted

22. and are in position!

Keep away from the working area and the danger areas of the machine!

23.

Keep away from the rotating and swivelling areas of the machine!

24.

Danger of crushing and shearing on (hydraulically) powered components!

25.

Secure the machine before leaving the tractor! Fully lower all hitched appliances! Turn off the engine and remove the ignition key!

26.

No one must enter the area between the tractor and the machine unless the vehicle is secured against rolling by means of the parking brake and/or chocks.

27.

28. Where, when fitted with front-mounted appliances, the front mounting dimension of 3.5 m (measured from the center of the steering wheel to the front point of the machine) is exceeded, the operator must ensure that the restricted field of vision when exiting from farmyards, pulling onto roads and at crossroads is compensated by suitable measures. This may be achieved, for example, by an accompanying person acting as lookout for the driver in such situations.

Hitched appliances

Before hitching and unhitching to and from the three-point linkage, set the operating device to a position which guards against unintentional raising or lowering!

1.

In three-point hitching, it is essential that the hitching categories of the tractor and the machine be identical or adapted to each other!

2.

There is risk of injury resulting from crushing and shearing in the vicinity of the three-point linkage!

3.

When the external control for the three-point hitching is operated, do not enter the area between the tractor and the machine!

4.

In the transit position of the machine, always ensure sufficient lateral arresting of the tractor three-point linkage!

5.

When driving on the road with the machine lifted, the operating lever for the three point hydraulic must be secured against lowering!

6.

Towed machinery

Secure the machines against rolling!

1.

Observe max. permissible support load of trailer coupling, drawbar or hitch!

2.

With drawbar towing, ensure adequate mobility at the drawbar connection point!

3.

Power take-off shaft operation

Only the powershafts specified by the manufacturer may be used!

1.

The protective pipe and funnel guard of the powershaft and the power take-off shaft guard must always be fitted and fully functional!

2.

In the case of powershafts, ensure observance of the specified pipe overlaps in transit and working positions!

3.

4. The powershaft must only be mounted and removed with the power take-off shaft and the engine switched off, and with the ignition key removed!
5. When using powershafts with overload or freewheel clutches which are not covered by the protective guards on the tractor, overload or freewheel clutches must be attached on the machine side!
6. Always ensure correct assembly and securing of the powershaft!
7. Secure the powershaft guard against being pulled along by attaching the chain!
8. Before switching on the power take-off shaft, ensure that the selected speed and direction of rotation of the tractor power take-off shaft correspond to those of the machine, as shown on the serial plate!
9. Before switching on the power take-off shaft, ensure that no one is in the danger area of the machine!
10. Never switch on the power take-off shaft with the engine switched off!
11. When working with the power take-off shaft, no one must be allowed in the area of the rotating shaft or the powershaft!
12. Always switch off the power take-off shaft if excessive offset angles of the pto-shaft occur, or when it is not required!
13. Caution: when the power take-off shaft has been switched off, danger from running-on as a result of centrifugal mass! During this time the machine must not be approached too closely. Work may only be carried out on the machine when all machine parts have come to a standstill!
14. Cleaning, lubrication or setting of the power take-off shaft driven machine or of the powershaft only with the power take-off shaft and the engine switched off, and with the ignition key removed!
15. Place the decoupled powershaft on the mounting provided!
16. After removing the powershaft, push the protective sheath onto the stump of the power take-off shaft!
17. Damage to the machine is to be rectified immediately, and the machine should not be used until this has been done!

Hydraulic system

1. The hydraulic system is under high pressure!
2. When connecting hydraulic cylinders, ensure correct connection of the hydraulic hoses!
When connecting hydraulic hoses to the tractor hydraulics, ensure that pressure is switched off both on the tractor side and on the machine side!
3. On hydraulic functional links between the tractor and the machine, the coupling sleeve and coupler plug should be clearly marked in order to prevent incorrect operation! If the links are wrongly connected the reverse function results (e.g. raising/lowering) - danger of accidents!
4. Regularly check hydraulic hose lines and replace if damage or ageing has occurred! The replacement lines must meet the technical requirements of the machine manufacturer! The service life of the hose lines should not exceed 6 years, including a storage life of not more than 2 years.
5. When searching for leaks use the proper equipment, otherwise there is danger of injury!
7. Fluids emerging under high pressure (hydraulic oil) may penetrate the skin and cause serious injury! If an injury occurs, see a doctor immediately! Danger of infection!

8. Before working on the hydraulic system, lower all appliances/assemblies, remove the pressure and switch off the engine!

Tyres

1. When working on the tyres it should be ensured that the machine is safely parked and secured against rolling (chocks)!
2. The fitting of tyres and wheels requires adequate knowledge and the proper tools!
3. Repair work to tyres and wheels may only be carried out by specialists using the appropriate tools and equipment!
4. Regularly check the air pressure! Observe specified air pressure!

Maintenance

1. Repair, maintenance and cleaning work, as well as the rectification of malfunctions, should only be carried out with the drive switched off and the engine at a standstill!- Remove the ignition key!
2. Regularly check nuts and screws for tightness, and retighten as necessary!
3. During maintenance work on raised appliances/assemblies, always secure with suitable support elements!
4. When replacing working equipment, use suitable tools and gloves!
5. Properly dispose of oils, greases and filters!
6. Before working on the electrical system, always disconnect the power!
7. If protective guards are subject to wear, they must be checked regularly and replaced at the appropriate times!
8. Spare parts must at least meet the technical requirements specified by the machine manufacturer! This is ensured, for example, by the use of original spare parts!
9. When carrying out electrical welding work on the tractor and hitched appliances, detach cables on the alternator and battery!

Haymaking machinery

1. The haymaker is designed, and suitable for, the processing of mown crop material lying on the ground!
2. When swivelling the drawbar from the transit position to the working position and vice versa, danger of crushing and shearing occurs at specific points! Particular care should be taken during swivelling!
3. Repairs to preloaded energy stores (springs, pressure accumulators etc.) require adequate knowledge and the proper tools, and may only be carried out in specialist workshops!

Read instructions before commissioning

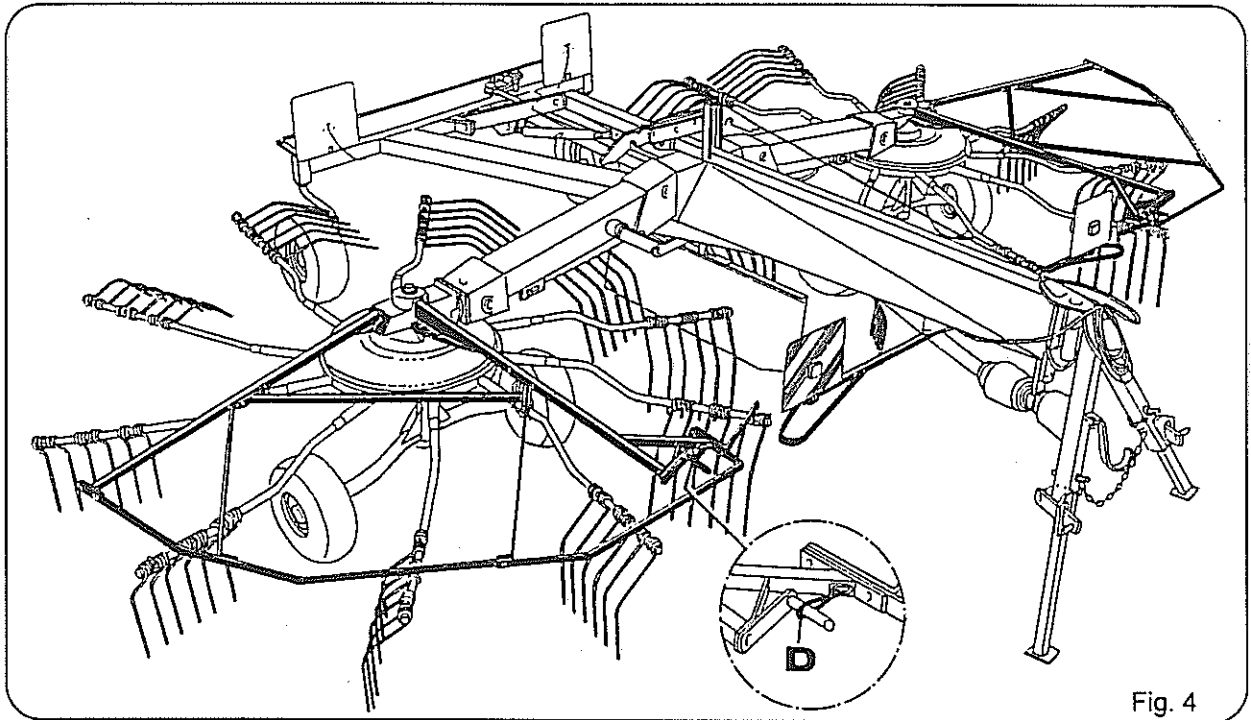

Fig. 4

1. The safety guard with crank handle for height adjustment of the rotor and centre safety frame must be attached (see fig. 4). Secure the crank handle on the left side as well as on the right side with the rubber band provided (fig. 4, pos. D).
2. Observe the pertinent regulations when using public traffic routes. The proper attachment and legibility of the warning signs with the lighting fixtures
3. **WARNING!** Damaged or bent tines should be changed before use due to the increased risk of accident.
4. Rotating parts of the rake operate at high speeds. This should be borne in mind at all times and all bearings and moving parts should be lubricated frequently and thoroughly. The function and service life of the rake directly depends on good lubrication and maintenance.
5. People must be kept away from the danger area, as there is a risk of injury from solid bodies which are expelled. Particular care is to be taken on public thoroughfares.
6. **WARNING!** As the running wheels are driven, the machine follows the tractor tracks. The back of the rake slews on curves.
7. If a braked power take-off shaft is used, a pto-shaft with overload safety system and free-wheel is recommended.
8. Compliance with the following instructions of this operating manual is necessary in order to prevent human errors.

Only use ORIGINAL NIEMEYER SPARE PARTS. Incorporation of other marks may cause serious damage and lead to the guarantee being declared invalid.



Copied parts and special parts subject to wear rarely fall in line with the requirements made. Material quality cannot be tested visually.

This is why you should always only use ORIGINAL NIEMEYER spare parts!

Hydraulik diagram

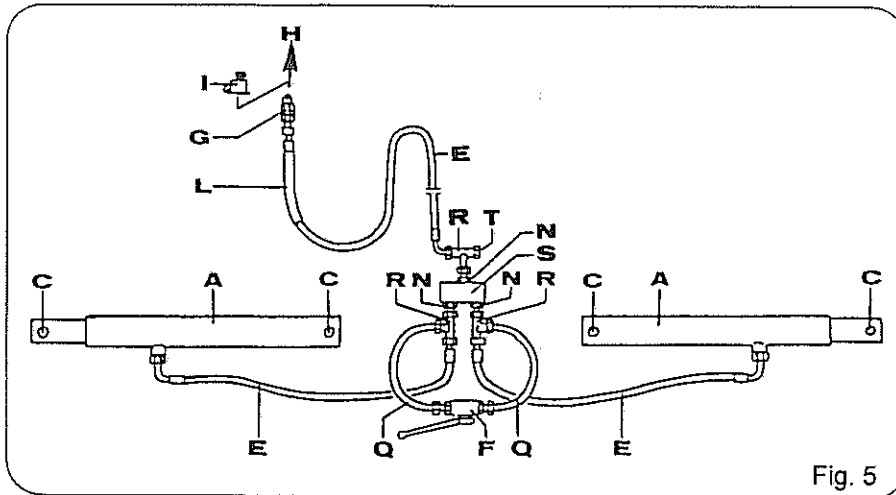

Fig. 5

RS 640 / RS 710 / RS 740-V

(Fig. 5)

- | | |
|--------------------------|----------------------------|
| A = Hydraulic cylinder | L = Protective hose |
| C = Equipment connection | N = Threaded connection |
| E = Hydraulic hose | Q = Hydraulic pipe |
| F = Stop valve | R = Threaded T-joint |
| G = Coupling connector | S = Valve-fuel distributor |
| H = Tractor | T = Blind plug |
| I = Connector bracket | |

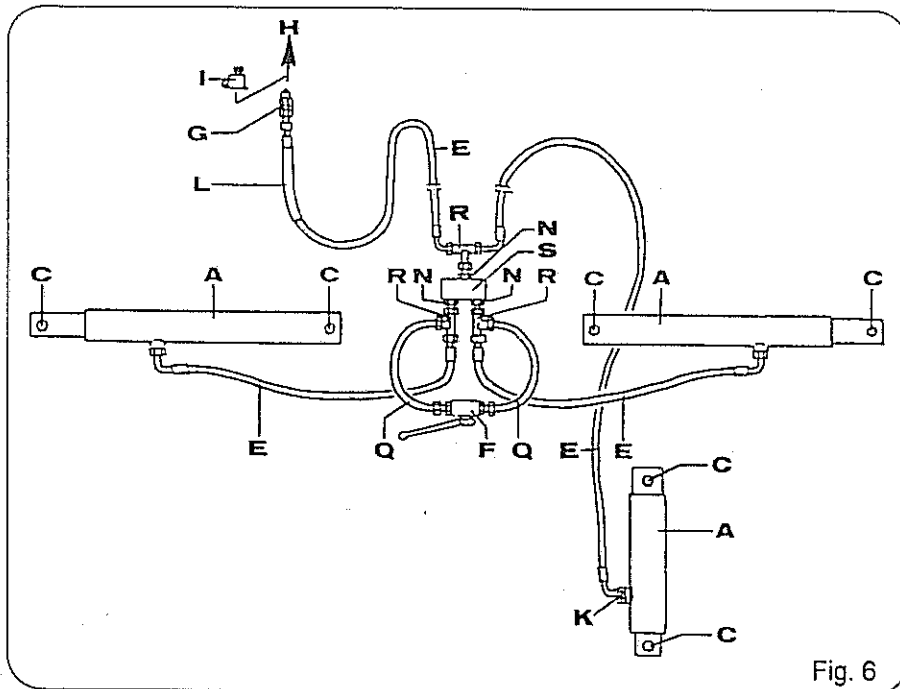

Fig. 6

RS 640 / RS 710 / RS 740-V

(Fig. 6)

- | | |
|--------------------------|----------------------------|
| A = Hydraulic cylinder | K = Sharp-edged orifice |
| C = Equipment connection | L = Protective hose |
| E = Hydraulic hose | N = Threaded connection |
| F = Stop valve | Q = Hydraulic pipe |
| G = Coupling connector | R = Threaded T-joint |
| H = Tractor | S = Valve-fuel distributor |
| I = Connector bracket | |

Attachment, Transport and Operation

Pto-shaft

The long pto-shaft (fig. 7, pos. R) leads from the front at the middle transmission to the intermediate bearing underneath the supporting trestle. It is already cut-to-length and assembled.

The short pto-shaft (fig. 7, pos. S) connects the tractor with the harrowing machine.

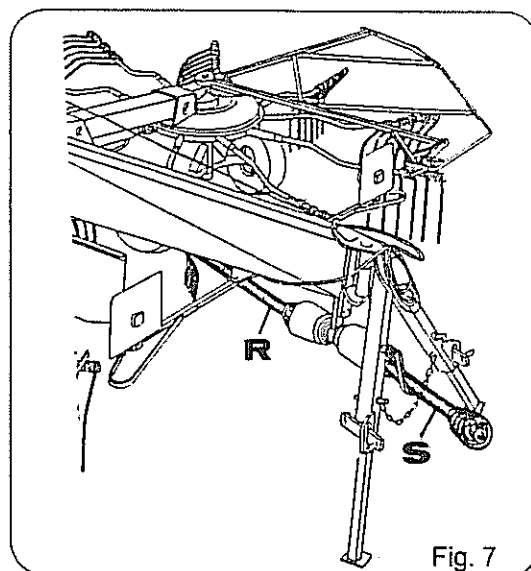

Before use, check length of pto-shaft and shorten if necessary. As the pto-shaft telescopes when travelling around curves and lifting out with the tractor hydraulics, if the pto-shaft is too long it may cause damage.

The pto-shaft should not rest on blocks nor should it be too short - the metal sleeve of the pto-shaft should insert at least 400 mm. **WARNING!** Risk of the pto-shaft breaking.

Measures to shorten the pto-shaft are described in the pto-shaft operating manual.

To shorten the pto-shaft, use metal saw to cut through sliding sleeve and protective sleeve. Abrasive cutting machines and suchlike should not be used due to heat effects which may damage the sliding sleeve. Remove swarf and chippings after shortening.

Lubrication: after shortening the pto-shaft and when in use lubricate sliding sleeve regularly from inside.

To protect against accident, the external protective sleeve of the pto-shaft should be chained to the frame.

In the operating instructions for the pto-shaft, the manufacturer gives important hints and tips on use of the pto-shaft.

Attachment and Transport

Stop the engine and remove the key if an assembly has to be done between the tractor and the high-performance rake (see warning symbol on page 20, pos. F).
Pay attention to relief of the front axle! Remaining load at least 20 % of the tractor.



Within the area of the three-point bar and the lifting limit of the back transport cylinder, there is a danger of injury by contusion and shearing (see warning sign on page 20, pos. N).

When attaching and removing the tractor, particular care should therefore be taken. The hydraulic system is under high pressure.

Before working on the hydraulics, release pressure and stop engine.

When connecting the hydraulic cylinders, check connection to hydraulic hoses as required.

There are shear and pinch points on all hydraulically actuated parts (see warning figures on page 20, pos. N).

Work on the hydraulic system should only be undertaken by a specialist.

Hydraulic lifting of the rotors should only be actuated if there is no-one in the danger zone (see warning figures on page 20, pos. D).

Check hydraulic lines regularly and replace of damaged or worn (see page 6 and 7 "Hydraulic device").

The attachment categories of the tractor and the unit must always match.

The high-performance rake may only be transported on public paths and roads with the folded up rotors, as otherwise the permissible maximum transport width (StVZO - German Federal Motor Vehicle Safety Standards) of 3 m will be exceeded. The maximum transport height (StVZO) of 4 m must also be observed (bridges, gate entrances etc.).

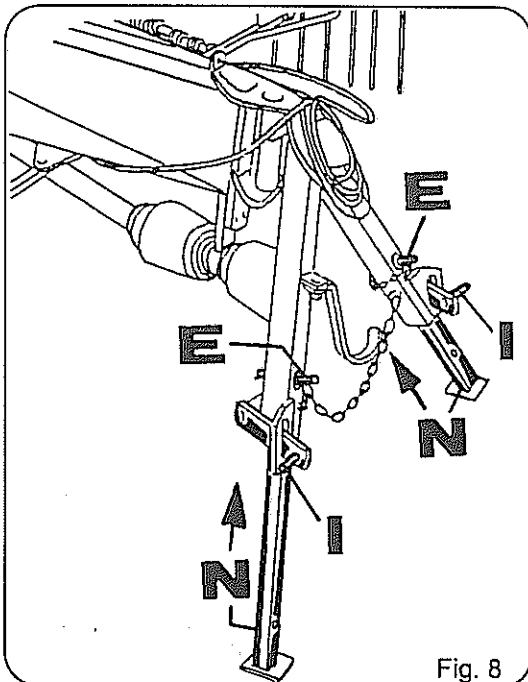

For transport, the rake is hooked onto the lower guide rod of the tractor (fig. 8, pos. I). After the lower guide rods have been raised by the three-point hydraulics, the stop supports (fig. 8, pos. N) can be inserted into the supporting trestle, positioned using the pins (fig. 8, pos. E) and secured by linchpins.

Connect hydraulic hoses to single-acting control valve on tractor.

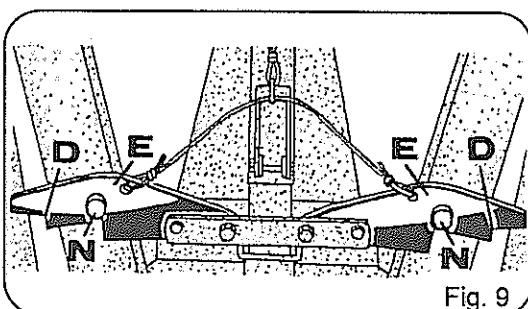

Release the ratchets (fig. 9, pos. E) by pulling cable and lift rotors hydraulically until it is vertical and lock latches in the second position (fig. 9, pos. N).

Ensure correct engagement of the catches.

Fig. 10 shows the RS 640 / RS 710 / RS 740-V in the transport position.

Dimension R:

RS 640	=	ca. 3,80 m
RS 710	=	ca. 3,90 m
RS 740-V	=	ca. 3,80 m

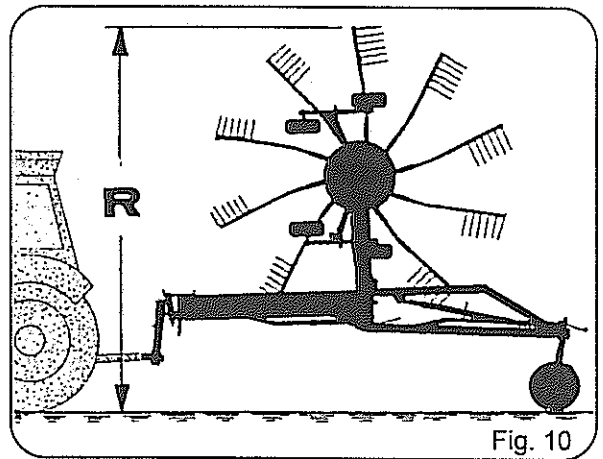

Fig. 10

For RS 640-S / RS 710-S / RS 740-VS only.

Activate the hydraulics valve and lift the frame supports (fig. 11, pos. A) with the cable (fig. 11, pos. E).

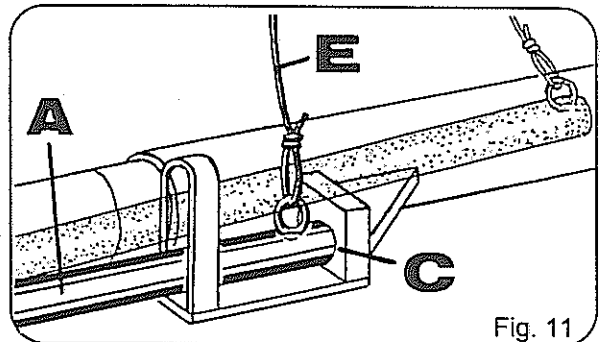

Fig. 11

Slowly lower the machine frame using the tractors hydraulics (fig. 12).

Dimension S:

RS 640-S	=	ca. 3,15 m
RS 710-S	=	ca. 3,25 m
RS 740-VS	=	ca. 3,15 m

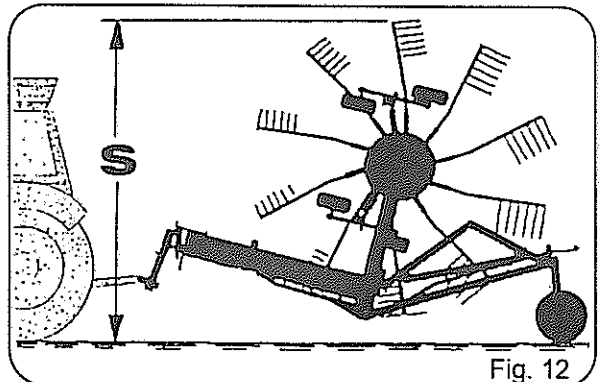

Fig. 12



A danger of contusion exists in the areas of pivoting points, the lifting limits (fig. 11, pos. C) and the hydraulic cylinders (see warning sign on page 20, pos. F).

Prior to transport on public routes and roads, it shall be observed that the catches are properly locked (see page 12, fig. 9, pos. N) and that the warning signs and lighting fixtures are clean and legible.

When the pto-shaft is attached transport can begin.

The P.T.O. must be switched off and the rotors completely stopped before transport.



A danger of contusion exists in the areas of the lifting limits of the extension arms and transport cylinders (S equipment), (see warning sign on page 20, pos. N).

It is not permitted to stand in the swinging and working area of the machine (see warning symbol on page 20, pos. D).

Operation

Before performing any work on the rotary rake, switch off the tractor engine, remove the ignition key and switch off the tractor P.T.O. (see warning symbol on page 20, pos. F).

The implement can rake fodder into windrows under the centre of the machine.

The rake is attached to the lower links of the tractor. The upper link is not used.

Before use, lock under links of tractor in position on one side.

An adequate safety distance from the swing-out range of the machine shall be maintained (see warning sign on page 20, pos. D).

It is prohibited to stand in the vicinity of the equipment when the engine is running and work is in progress (see warning sign on page 20, pos. A).

It must be observed that the driving speed of the motor for the tractor power take-off shaft matches the prescribed speed for the machine (see identification plate).

Never exceed the maximum speed given for the machine.

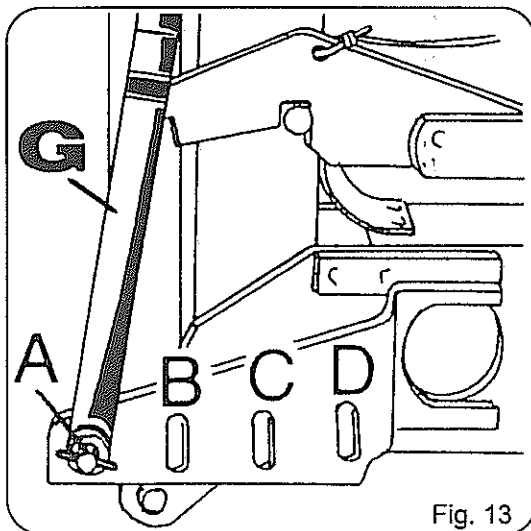

Fig. 13

For RS 740-V / RS 740-VS only

Using the left and right adjusting lever (fig. 13, pos. G), the required working width can be set. To adjust, the rotor must be raised.

When it is lowered, the rotor then inserts in the required working position.

Working width: in hole A 7.30 m approx.
 in hole D 6.70 m approx.

The catches should be undone by pulling the cable on the tractor and the rotor then lowered hydraulically until the running wheels rest on the ground under the rotor.

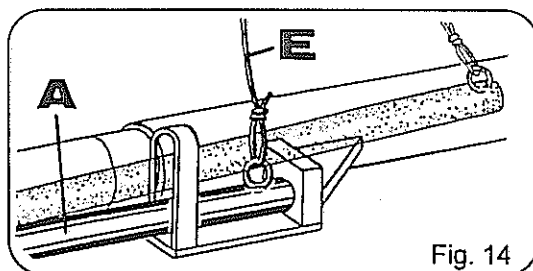

Fig. 14

For RS 640-S / RS 710-S / RS 740-VS only

Raise the machine frame using the tractor hydraulics.

Verify that the frame supports (fig. 14, pos. A) are in position as shown.

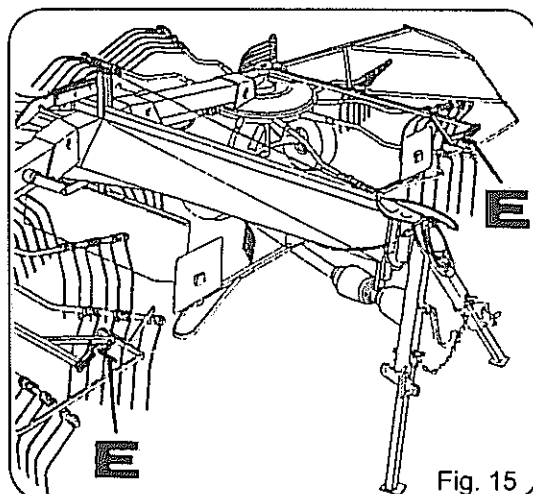

Fig. 15

Adjust rotor with the crank handle on the right and left (fig. 15, pos. E) until the tines no longer touch the ground.

Adjust the unit with the tractor hydraulics to the correct working height and fix the sling chain on the tractor so that this working height is maintained. The stop chain is to be mounted on the tractor so that it runs at the steepest angle possible.

The swath width can be adapted to suit the fodder concerned by turning the cam track (adjusting plate under rotor, fig. 16).

Do not set the cam disc pin in holes A and E (facing toward machine centre).



If the cam disc is adjusted with the machine raised, then it must always be supported and secured against accidental lowering.

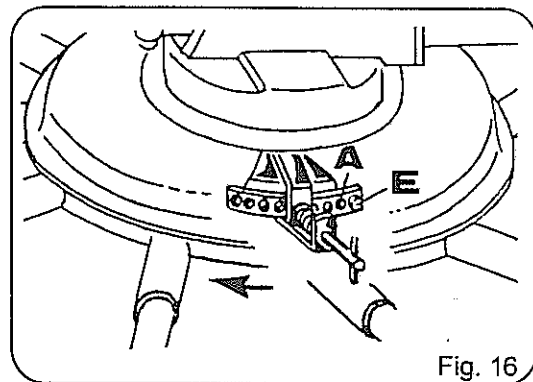

Fig. 16

The travelling speed and power take-off shaft speed should be selected such that the crop comes away cleanly from the tines.

For gathering with a circular harrow, one of the two circular harrows must be locked with the transport catch in accordance with fig. 17, pos. A. In order to fast-raise and fast-lower one circular harrow only, position the lever of the cut-off valve behind the middle transmission into the position D (fig. 17). The raised circular harrow will rotate as well when gathering.

Observe a correct locking of the catches.

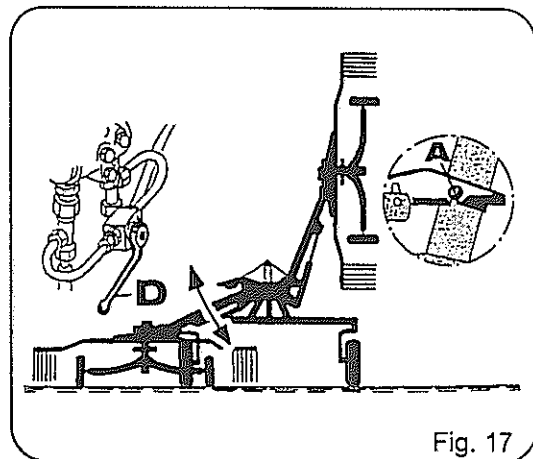

Fig. 17

For gathering using both circular harrows, position the lever of the cut-off valve into position E (fig. 18) in order to ensure a balanced raising and lowering of both circular harrows.

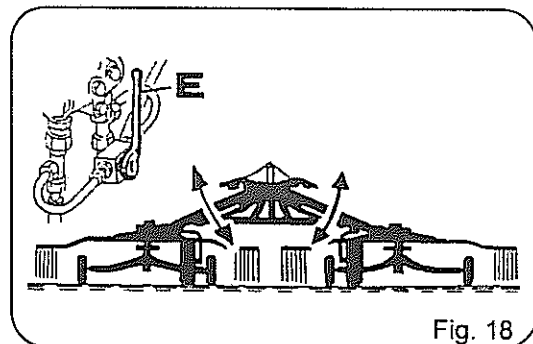

Fig. 18

To travel over crosswise windrows in the forward crop section, both rotors can easily be raised while working (lever position fig. 18, pos. E).

The stop on the catches (see page 12, fig. 9, pos. D) limits the extraction height automatically. The drive does not therefore need to be disconnected.



Do not touch moving machine parts. Wait until they have come to a complete stop (see warning symbol on page 20, pos. E).

The rake can also be used to gather several straw windrows into one (e.g. wide combine harvesters).

Adjustable running wheel

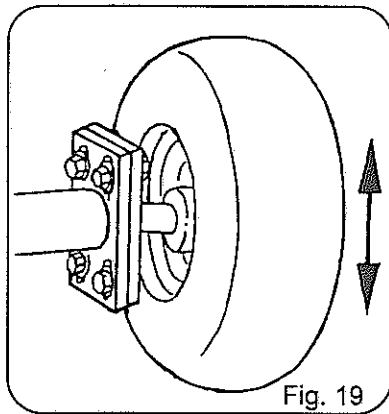

The carriage frame underneath the circular harrow is fitted with a flanged connection on each side. The running wheel can be moved continuously by approx. 1.5 cm upward and downward in the slotted holes (fig. 19).

In this way even raking from the left to the right side of a rotor can be adjusted in accordance with the fodder conditions.

After the adjustment firmly retighten the bolts.
Tightening torque = 41 Nm.



The adjustment should be carried out with the machine raised. In this case the high-performance rake must always be secured against accidental lowering.

Overload safety system

If the overload safety system of the pto-shaft is operated repeatedly (e.g. with excessive fodder thickness), a lower gear should be selected. If the overload safety system runs for longer than 10 seconds, stop and find out why to prevent damage to the overload coupling.

Storing the high-performance rake

The high-performance rake can be lowered down in the working position as well as into the transport position.

The machine can be stored with the circular harrows in the upright position (transport position) in order to make the storage space for this as small as possible when outside of the working season. The high-performance rake should always be lowered down on to firm and level ground.

Lowering down in the working position

- Set machine in transport position.
- Remove supports and secure (see Page 14, fig. 16).
- Place pto-shaft removed from tractor in holder provided.
- Disconnect the hydraulic plug and insert this into the empty socket of the machine frame.
- Disconnect the cable connections for the lighting fixtures from the tractor.

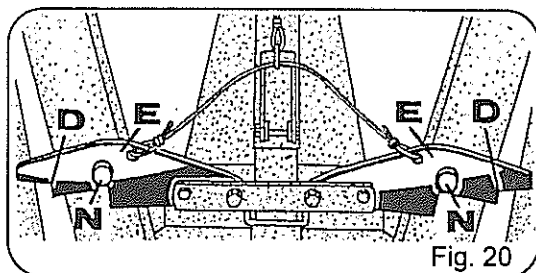

- Set machine in transport position.
- Set catch as shown in fig. 20. Ensure correct locking.
- Remove supports and secure (see Page 12, fig. 8).
- Place pto-shaft removed from tractor in holder provided (Page 11, fig. 7, pos. S).
- Disconnect the hydraulic plug and insert this into the empty socket of the machine frame.
- Disconnect the cable connections for the lighting fixtures from the tractor.



After harvesting or after extended periods of storage in the open air, the piston rods of the hydraulic cylinder should be cleaned and maintained with acid-free grease.

Care and Maintenance



Before starting maintenance or repair work stop the engine of the tractor and remove the key (see warning symbol on page 20, pos. F).
If the equipment is raised by this, then it is imperative that it is secured to prevent any unintentional subsequent sinking.

Lowering down in the transport position

All bearing positions shall be sealed such that the equipment can be cleaned with water jets after each use.

Following the first use as well as after an operational period of approximately 2 hours, all bolts shall be

Maximum torque for hexagon head screws with standard metric ISO thread

Thread diameter	Torque M in NM				
	5.6	6.9	8.8	10.9	12.9
M 5	2,8	5	6	8,5	10
M 6	4,7	8,5	10	14	17
M 8	12	21	25	35	41
M 10	23	41	49	69	83
M 12	40	72	86	120	145
M 14	64	115	135	190	230
M 16	100	180	210	295	355
M 18	135	245	290	405	485
M 20	190	345	410	580	690
M 22	260	465	550	780	930
M 24	330	600	710	1000	1200
M 27	500	890	1050	1500	1800
M 30	670	1200	1450	2000	2400

To ensure screws and nuts sit correctly, these should be properly tightened. Use a torque wrench for this. The required screw torque should be read off the schedule.

Example: An M 8 screw for fixing class 8.8 should be tightened to a torque of 25 Nm = 2.5 mkg. The strength is indicated at the top of the screw.

Care and Maintenance

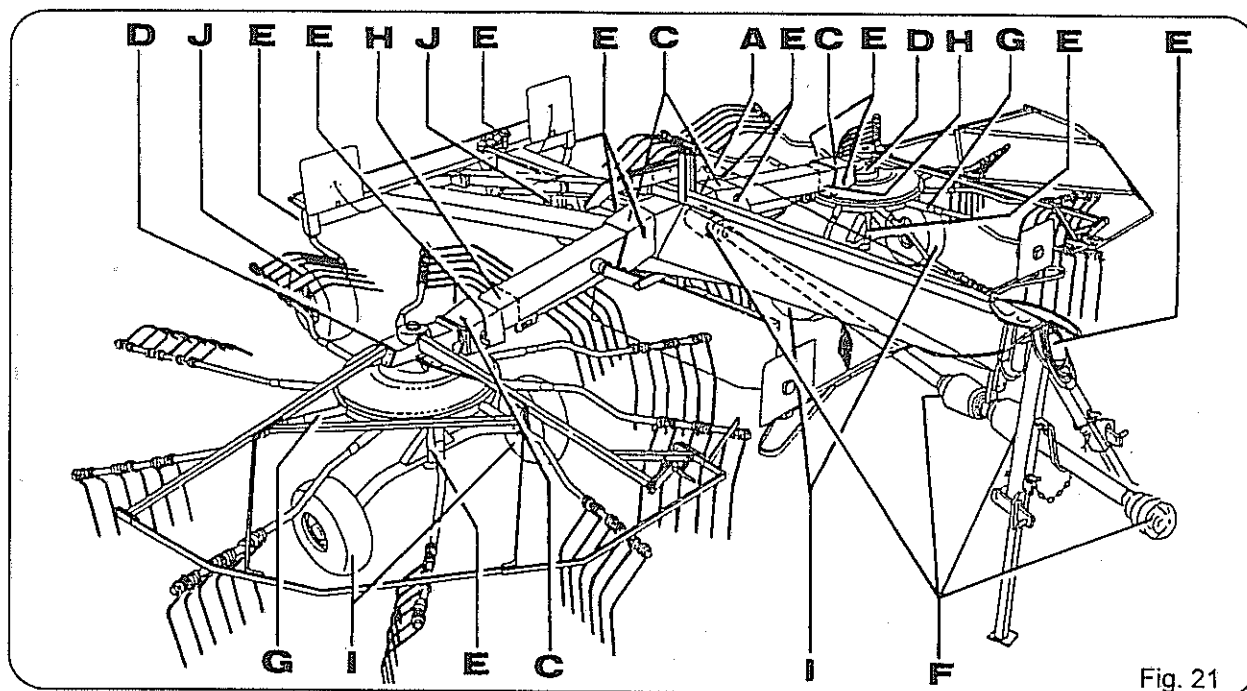

Fig. 21

The rotor gearing (fig. 21, pos. D) should be lubricated with cup grease before using for the first time (lubricating nipple on gearing). The rotors should be rotated slowly by hand to ensure even lubrication. Lubricate again every 8 hours of operation.

Before operating, all 20 tine holders should be lubricated (fig. 21, pos. G) so that grease emerges on both sides of the bearing. During the period in use, the tine arm bearings as well as all other points of lubrication with lube nipples (fig. 21, pos. C, E, F) shall be lubricated adequately and every week, pos. C = lube nipple at the cross-joint and pos. F = lube nipple at the cross-joint of the pto-shaft. All stop, swivel bolts and multi-spline profiles should likewise be oiled each week.

The centre gearing is filled with free-flowing grease. The filler plug is on the central gearing at the top of the gear (fig. 21, pos. A). Before each season, the operator should check for correct gear lubrication and top up the grease in the gearing.

The pneumatic tyres on the rotors running wheels (fig. 21, pos. I) require a tyre pressure of 1.5 bar. The chassis wheels (fig. 21, pos. J) require a pressure of 2.0 bar. All wheels should be checked regularly for the correct air pressure.

After harvesting or after extended periods of storage in the open air, the piston rods of the hydraulic cylinder should be cleaned and maintained with acid-free grease.

Optional Extras

Quadro chassis

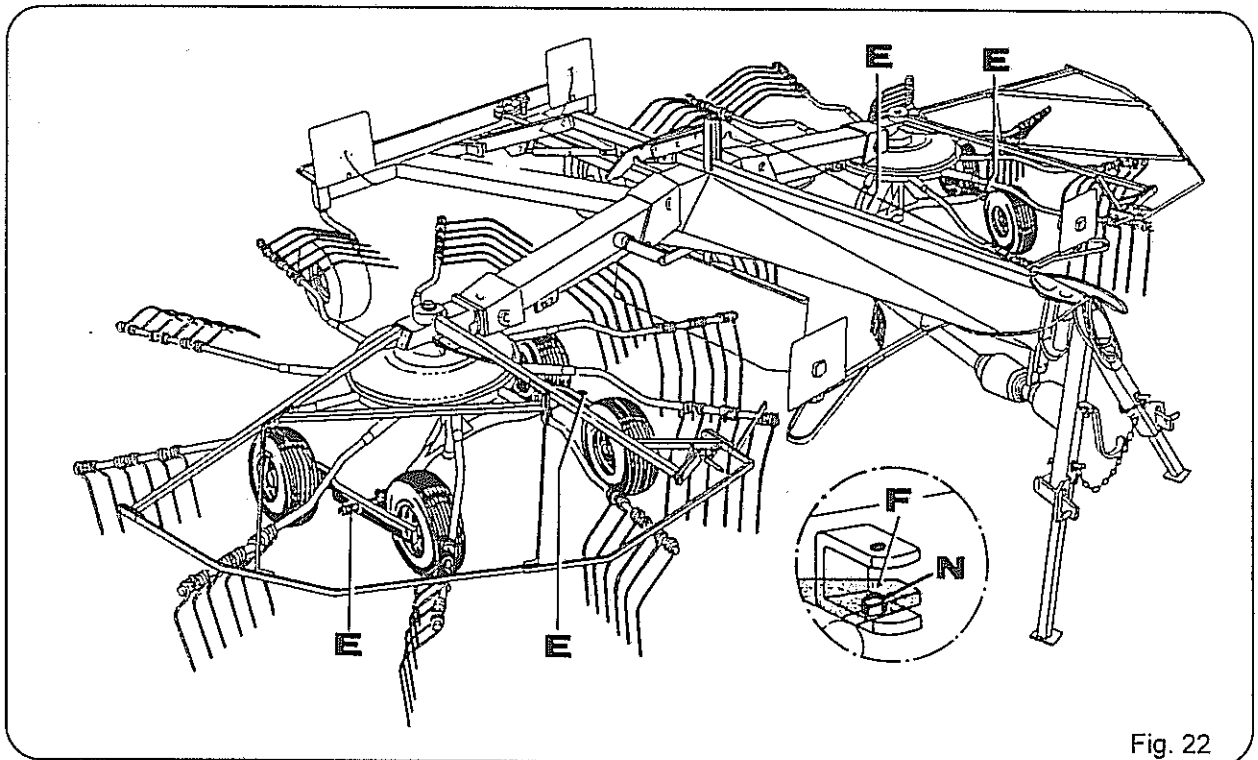

Fig. 22

Pay attention to proper of the Quadro chassis!

The axles of the Quadro chassis are placed on the wheel of the chassis instead of the running wheels (see fig. 22). The stops (fig. 22, pos. F) must lie in the clamps. The stop screw (fig. 22, pos. N) must point downwards left and right. The nuts must then be tightened securely on the wheel axles again.

The lubricating nipples on the quadro axles should be greased regularly when in use (pos. E).

Warning symbols

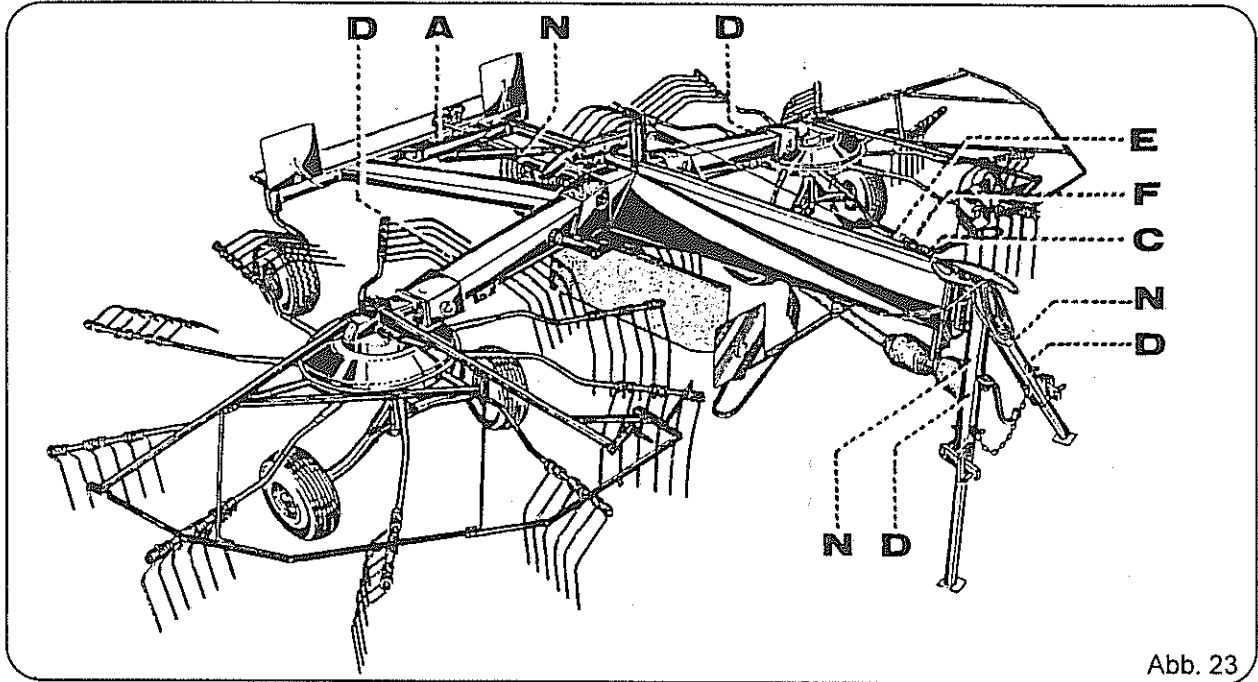

Keep distance with motor running.

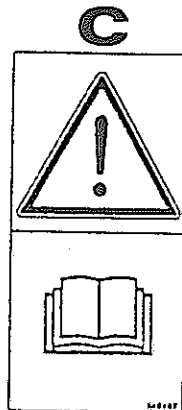

Read and pay attention to operating instructions and safety information before starting for the first time.



Maintain adequate safety distance to the swing area of the machine.

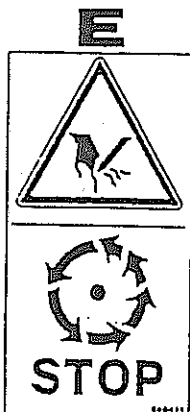

Do not touch any moving machine parts. Wait until they have come to a complete standstill.

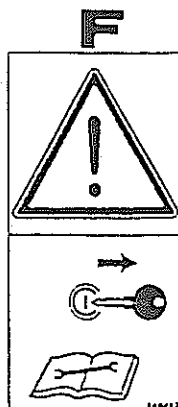

Before maintenance and repair work, stop the motor and remove the key.

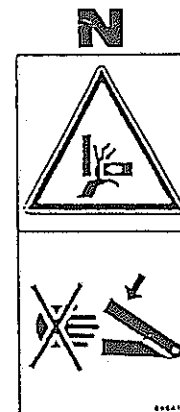

Never reach into the crushing danger zone as long as parts are moving there.

Warning symbols



Abb. 23



Keep distance with motor running.

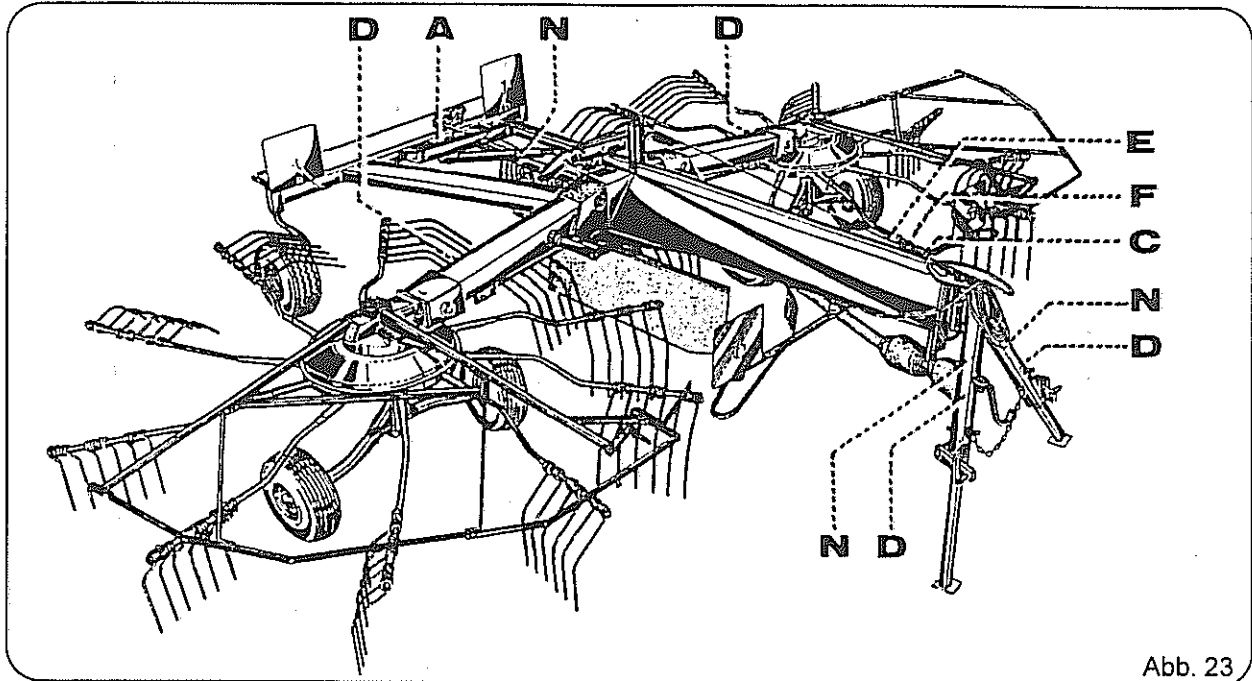
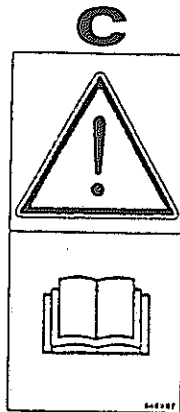

Read and pay attention to operating instructions and safety information before starting for the first time.



Maintain adequate safety distance to the swing area of the machine.

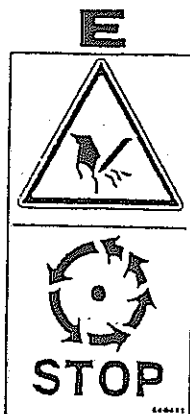

Do not touch any moving machine parts. Wait until they have come to a complete standstill.

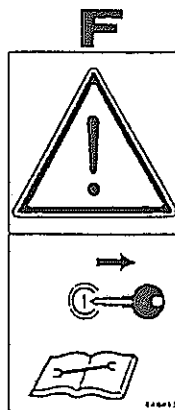

Before maintenance and repair work, stop the motor and remove the key.

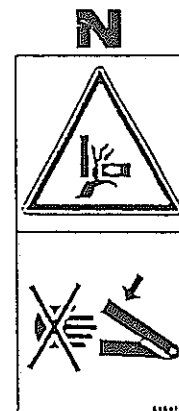

Never reach into the crushing danger zone as long as parts are moving there.

1295
0456
0194

RS 640 / RS 620-S
RS 710 / RS 71-S
RS 740-V / RS740-VS